

# CERTIFIED INSTALLER GUIDEBOOK

**PROCEDURES &  
INSTALLATION DIAGRAMS**





## TABLE OF CONTENTS

Introduction.....	p. 3	SIM Swap (MGS800).....	p.15
Installer’s Toolbox.....	p. 4	Emergency Button Install.....	p. 16
Important Note.....	p. 5	SCHEMATIC: MGS + Emergency Button.....	p. 17
LED Signals for MGS80.....	p. 7	SCHEMATIC: MGS + Driver ID.....	p. 18
Troubleshooting Steps for MGS800.....	p. 8	SCHEMATIC: MGS + Door Sensor.....	p. 19
Troubleshooting On-Site Process.....	p. 12	SCHEMATIC: MGS + PTO.....	p. 20
Invoicing.....	p. 13	SCHEMATIC: MGS + RF Switch.....	p. 21
MGS800 OBD-II.....	p. 14	SCHEMATIC: MGS + Temp Sensor.....	p. 22



## INTRODUCTION

We - Fleet Complete Team - pride ourselves on building strong lasting partnership with contractors and our customers. We have a dedicated team of Technical Support members and a strong Training Team here in Australia.

This guidebook is designed to outline our procedures, installation guides for a variety of products and basic troubleshooting information.

For in-depth Technical Support, please contact 1300 653 395.

INSTALLER'S TOOLBOX





## INSTALLER'S TOOLBOX

### Most installations will require the following tools:

- Full compliment of various screw drivers
- Crimping tool for crimp connectors
- Wire cutters and strippers
- Quality heavy-duty or electrical tape
- Ring, spade, splice crimp connectors (red and blue)
- Small spools of red and black 18-20 gauge wire
- Digital multimeter
- Heavy-duty cable ties
- Silicone
- Rubber grommets
- Soldering iron and solder



IMPORTANT NOTE





## IMPORTANT!

### PLEASE READ THE FOLLOWING BEFORE PERFORMING ANY INSTALLATIONS

- Mount the devices away from any places of high moisture (i.e. under seats, floors, etc), sunlight or excessive heat.
- The Hardwire MGS Kit is shipped with one in-line 3-amp fuse attached to the power cable. This fuse must be installed as close as possible to the primary 12v source connection. The fuse protects the power cable should there be a short in the cable between the fuse and the MGS. If the fuse is replaced, it should be of the same type as originally supplied from the factory. Failure to use the proper fuse or to install the fuse in the recommended location could cause a vehicle fire hazard. The fuse provides overload protection for the power cable and MGS. The wiring installed between the fuse and primary vehicle power is not protected from overheating if a short should occur. Use care when routing the power cable and fuse. Route the cables where they will be protected and uses include commonly accepted install practices for after market automotive electronic devices.
- There are two acceptable methods of making a wire connection. You can solder the 12v Constant Power and Ground cables to the vehicles power center. Or you can crimp connectors with the use of the proper crimping tool. **Never use “t-tap”** connectors (poor quality mechanical type connection). **Never “twist and tape” without soldering** your connection. Never connect wires straight to the fuse box.





- Use high quality electrical tape or shrink tubing, cheap tape will unravel in hot weather making it a poor insulator.
- Insulate the wires not being used on the wire harness during the installation. Improper insulation could result in inaccurate notifications and increased usage on monthly billing.
- Hardwired MGS is connected directly to the vehicle's 12v system. There is no on/ off switch on the unit and it operates 24 hours a day.

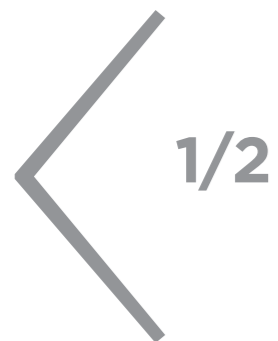



## LED SIGNALS for MGS800

When the ignition is first turned on the MGS will power-up. The Green LED will show solid for approximately 30 seconds. At no other time should green LED remain on solid for such a long period.

After 30 seconds the green LED will start to flash at the following rates:

- 25 times on-off every 10 seconds when the ignition is on (this is quite rapid)
- 8 times on-off every 10 seconds when the ignition is off (this is quite slow)
- Very short blip once every 3 seconds when in sleep mode
- The green LED will also show if there is a active input by flashing a number of times corresponding to the input (1, 2, 3, 4). For example, if input 4-Alarm is active then there will be 4 short flashes every 3 seconds.

### GREEN

- OFF Power down mode
- FLASH Low power mode
- SLOW Full power Ignition OFF
- FAST Full power Ignition ON

### RED

- OFF No faults detected
- 1 - 1 License key expired
- 1 - 2 Low Supply Voltage
- 1 - 3 Allocated Data Usage Exhausted
- 2 - 1 HSPA Module Fault
- 2 - 2 Not Activated
- 2 - 3 No HSPA Signal
- 2 - 4 Network not found
- 2 - 5 Last Data Session Failed
- 2 - 6 Data Plan is not available
- 3 - 1 GPS Module Fault
- 3 - 2 GPS Antenna open/short
- 3 - 3 GPS no track (0 sat.)
- 3 - 4 GPS no x (< 3 sat)
- 3 - 5 GPS no time
- 4 - 2 Data Transfer Failed

**TROUBLESHOOTING STEPS**





## TROUBLESHOOTING STEPS for MGS800

If after an Install the device is not reporting, please reference the following troubleshooting steps.

### Green LED

When the MGS is first powered ON, the green LED will show solid for approx 30 seconds. After 30 seconds the green LED will start to flash in the following pattern:

- Rapid flashing when Ignition is ON.
- Slow flashing when Ignition is OFF.
- Very short blips every 3 seconds, when the MGS800 is in sleep mode after Ignition OFF.
- The green LED will also display if any PTO or inputs are active. If for example INPUT # 3 is ON, the green LED will flash 3 short flashes every 3 seconds.

RED LED







## Red LED

The red LED will flash 2 digit error codes indicating which area of service is having a problem:

### 1 – X error codes: MGS specific errors

- 1 – 1 : License Expiry. The MGS license has expired or the license information is incorrect. Please record the serial number and ESN/IMEI of the MGS and contact Fleet Complete Technical Support for assistance.
- 1 – 2 : Low Supply Voltage. This could be due to low voltage conditions (<8v) or improper voltage supply the dips in voltage when the current draw spikes due to the modem trying to transmit data. Please check the voltage supply with meter.
- 1 – 3 : Allocated Data Usage Exhausted. The MGS requires a RESYNC command, please contact Fleet Complete Technical Support for assistance.

### 2 – X error codes: Modem specific errors

- 2 – 1 : Modem Module Fault. Please contact Fleet Complete Technical Support for assistance 1800 653 395.
- 2 – 2 : No SIM Inserted. Open the MGS from the side that has the antenna connectors. Pull out the board and locate the SIM card holder. Make sure that there is a SIM and it is inserted correctly.
- 2 – 3 : No Cellular Signal. Check the cellular antenna connection. Try to swap antenna with a known working antenna and re-power the MGS device. If problem persists contact Fleet Complete Technical Support for assistance 1800 653 395.

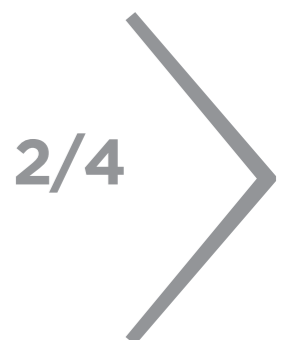



- 2 – 4 : Network Not Found. For GSM or HSPA devices, try another working SIM. For CDMA devices try dialing the ph # assigned to the current MGS. You may or may not get a message from the service provider indicating account disconnection. If not disconnected, re-power the device and if problem still persists contact Fleet Complete Technical Support for assistance 1300 653 395.
- 2 – 5 : Last Data Session failed. This means that the device lost its data connection to the server. It could be due to a number of reasons for example: account problem, network outage and poor coverage. Try re-powering the MGS and if problem still persists contact Fleet Complete Technical Support for assistance 1300 653 395.
- 2 – 6 : Data Plan is not available. This is an account configuration issue and you will have to contact Fleet Complete Technical Support for assistance or the service provider for the cellular account.

### 3 – X error codes: GPS specific errors

- 3 – 1 : GPS Module Fault. Please contact Fleet Complete Technical Support for assistance 300 653 395.
- 3 – 2 : GPS Antenna Fault. Check the antenna connectors, try to undo and redo the antenna connectors. If still unresolved, try another antenna and re-power. Wait 2 minutes and check LED's, if problem still persists then contact Fleet Complete Technical Support for assistance 1300 653 395.





- 3 – 3 : GPS not tracking any satellites. Make sure that the antenna (or a device with built-in antenna) has a clear line of sight to the sky. Re-position the antenna and wait 5 minutes to check LED codes. If problem still persists contact Fleet Complete Technical Support for assistance 1300 653 395.
- 3 – 4 : GPS No Fix. The GPS antenna is only able to utilise < 3 satellites in view. If the vehicle is in close proximity to a building, try relocating the vehicle. If the vehicle has a full view of the sky and the error condition still persists after waiting 5 minutes, then contact Fleet Complete Technical Support for assistance.
- 3 – 5 : GPS has no time. The internal GPS receiver is not able to get date and time from the satellites. This could occur if the GPS receiver has never been able to lock on to a satellite since it was last power cycled.

#### **4 – X error codes: End to End Application specific errors**

- 4 – 2 : Data Transfer Failed. The MGS had a problem sending/receiving data from the server. Please note that this can happen from time to time on a perfectly healthy MGS and is not indication of a hardware defect or installation problem. Trigger ignition state ON or OFF and this will initiate another data transfer to take place.

**DO NOT remove any hardware without contacting the Fleet Complete Technical Support department first. Any removal of hardware without the consultation of the Fleet Complete Technical Support team will not be warranted.**



**DISPATCH PROCESS**





## TROUBLESHOOTING ON-SITE

### SERVICE CALL DURING NET NEW INSTALL

If a technical issue with the hardware has been detected at the time of Net New Install, installer is to run basic troubleshooting steps outlined on page 21. If the issue persists, installer is to contact Fleet Complete Technical Support while on-site. Technical Support will open a CASE regarding the issue.

### NEW SERVICE CALL

Installer is to perform the troubleshooting steps outlined in the Installer Portal Job Request while at customer's location. If the issue persists, installer is to contact Fleet Complete Technical Support while on-site.

Upon completion of the work, installer is to contact Fleet Complete Technical Support to confirm that the issue has been resolved. **It is Installer's responsibility to ensure the device is reporting properly before they leave the site.**

INVOICING





## INVOICING

Installer is eligible to be reimbursed for the completed work as per the agreed upon price list in the Certified Installer Agreement or the Price Quote defined in the Installer Portal Job Request. Fleet Complete is responsible to pay the installer within 30 days of submission of the invoice only for the agreed upon charges.





## MGS800 INSTALLATION WITH OBD-II

- Locate the OBD-II Port in your vehicle which is usually under the dashboard left of your steering wheel. Or consult your owner's manual to locate it.
- Connect the OBD-II connector on the MGS to the OBD-II socket in your vehicle.
- Secure the MGS and the wiring under the dashboard to avoid breakage. The MGS must be installed with the label facing the sky with the MGS as close to the top of the dashboard as possible and kept clear of foot pedals.
- Update the asset with Vehicle ID, VIN and Odometer reading via support 1300 653 395 in Confirm the job as complete.

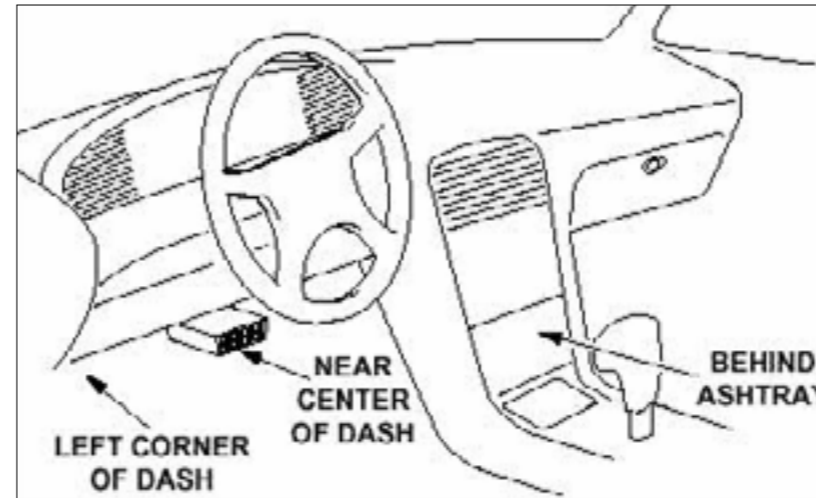

**Watch 2-min video**

### Each Kit includes:

- MGS800 Device
- OBD-II Cable





## SIM SWAP INSTRUCTIONS MGS800

**There are two types of GSM modems: plastic and metal enclosures.**

- Open the modems to get access to the internal circuit board. To open a plastic modem, use the flathead screwdriver to lift the two latches on one side of the modem. To open a metal modem, use a Phillips screwdriver to open the four screws on the front panel of the modem.
- Once opened, locate the SIM card slot on the bottom of the circuit board.
- Remove the old SIM card and place the new SIM card in the slot and secure the holder.
- Please make sure to note down the IMEI number of the SIM being removed and of the SIM card being inserted. The 19 digit IMEI number can be found on the SIM card itself.
- Once replaced, close the SIM card holder securely and gently put the circuit board back into its place inside the modem.
- Close the plastic modem by snapping the cover back onto the bottom panel. Close the metal modem by sliding the circuit board back inside the modem and screwing the four screws back to the front panel.
- Power up the MGS modem and after it has initialised, wait five minutes. The new SIM card will receive programming codes from the network provider.
- After a period of 5 minutes, trigger ignition state from ON to OFF and confirm, if the modem is now reporting.

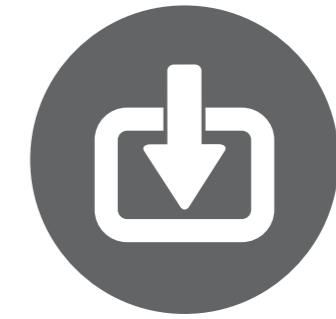

**Download complete  
SIM Swap Instructions**

**EMERGENCY BUTTON  
INSTALL**







## EMERGENCY BUTTON INSTALL

### INSTALLATION

- Run the Brown wire of Emergency Button connects to Input #4 on the power harness.
- Run the Black ground wire from the harness to the black wire on the Emergency Button.
- Run the Red power wire from the Emergency Button to a +12v constant power source on the MGS harness.
- Login to the Installer Portal
- Add Emergency Button as an input to the accessories of the serial number in the dispatched job details.
- Update ODO and VIN.
- After set up, test the switch.

**SCHEMATIC:**  
MGS800 + EMERGENCY BUTTON







# MGS800 + EMERGENCY BUTTON

20	18	16	14	12	10	8	6	4	2
19	17	15	13	11	9	7	5	3	1

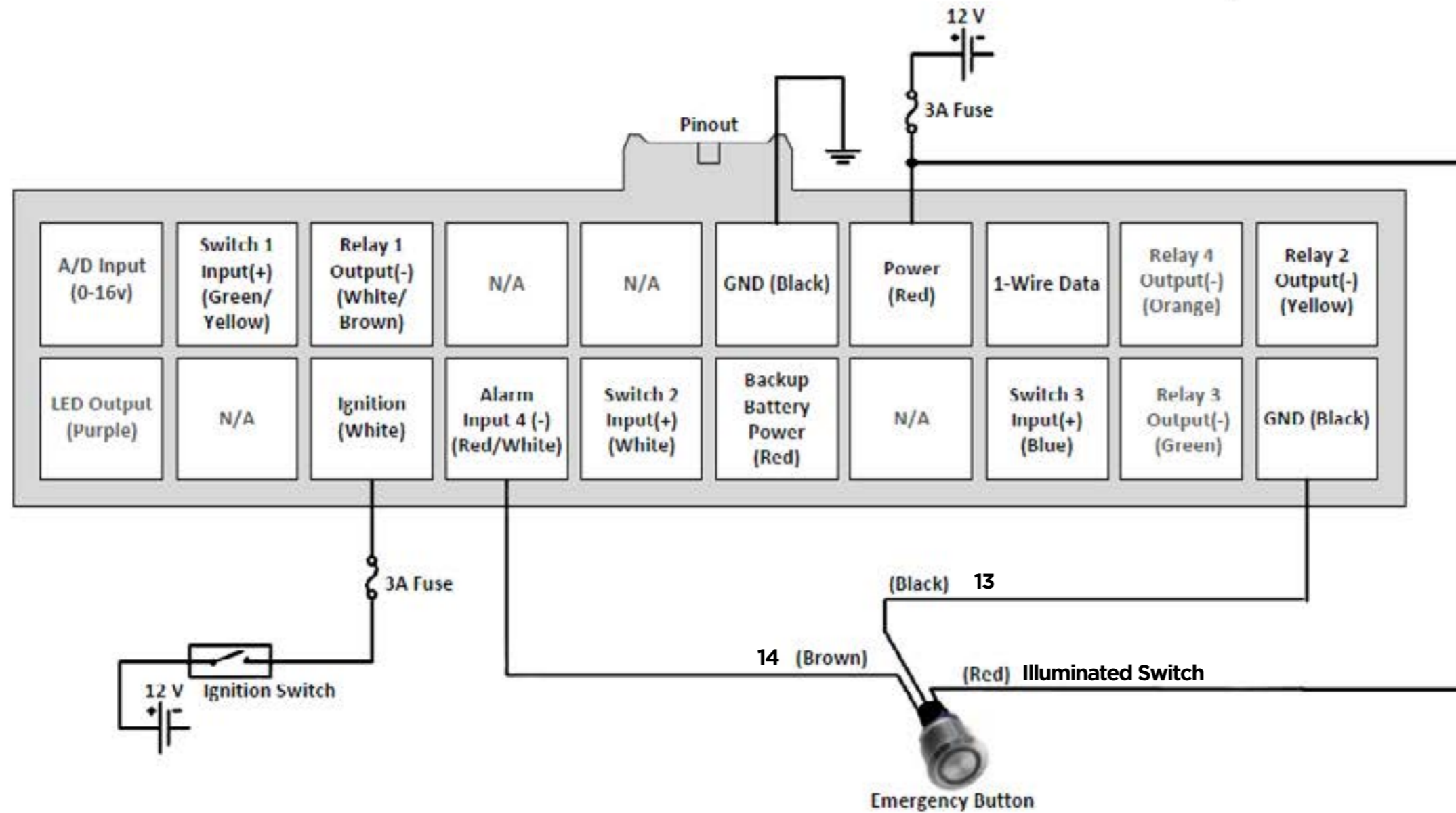

**SCHEMATIC:**  
MGS800 + DRIVER ID



# MGS800 + DRIVER ID

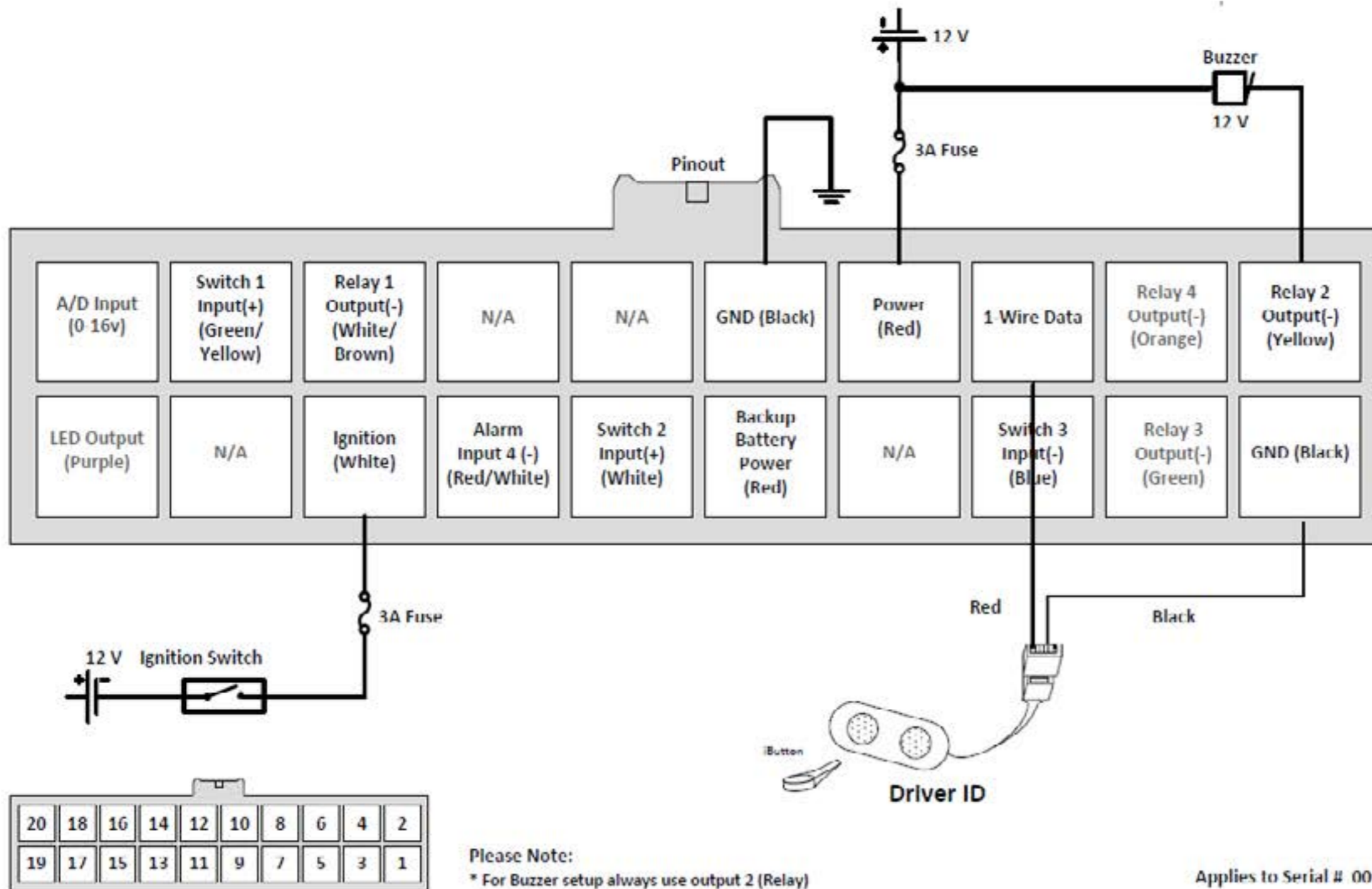

**SCHEMATIC:**  
MGS800 + DOOR SENSOR



# MGS800 + DOOR SENSOR

Applies to serial # 000003260000 and newer

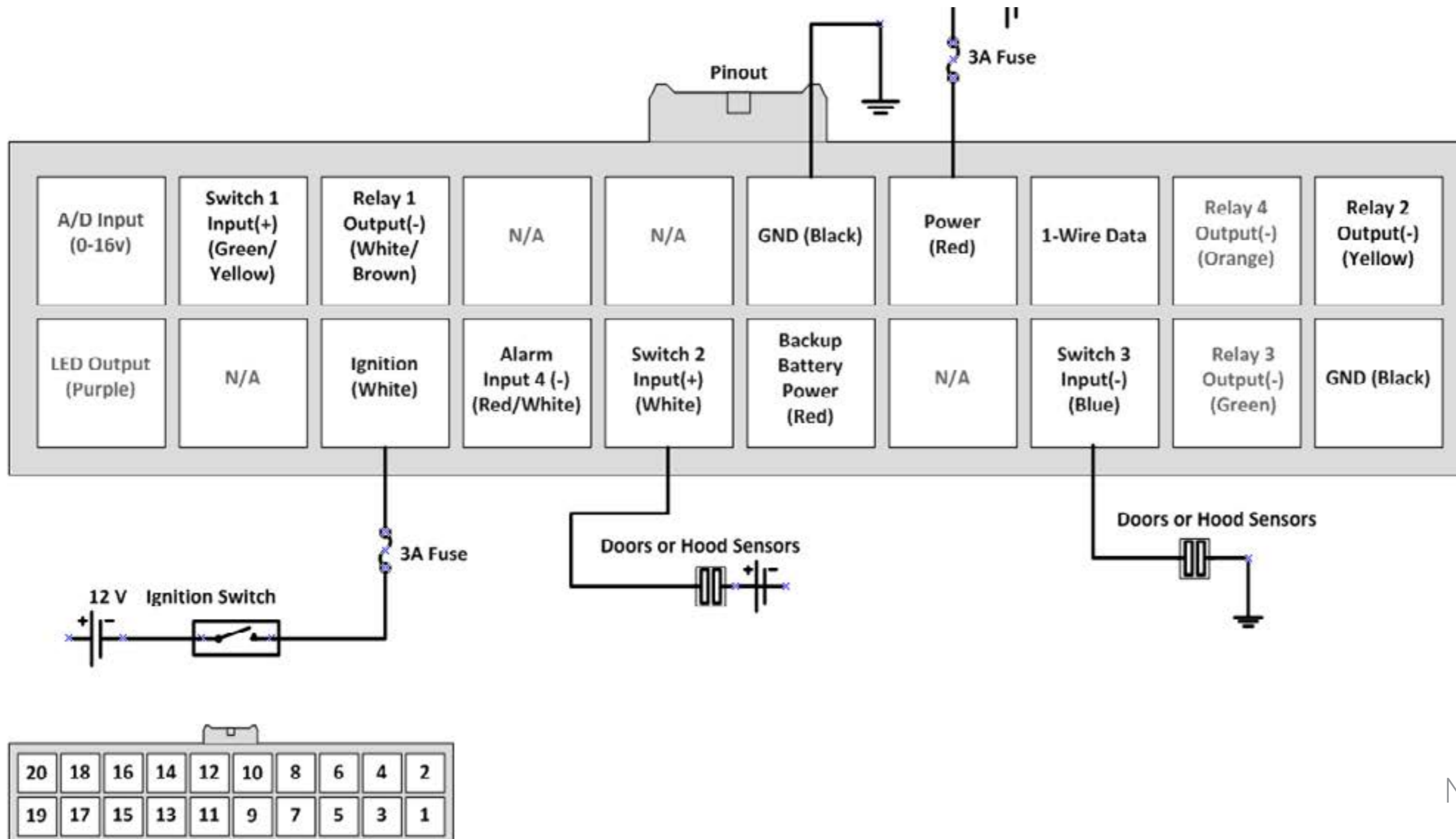

**SCHEMATIC:**  
MGS800 + PTO



# MGS800 + PTO

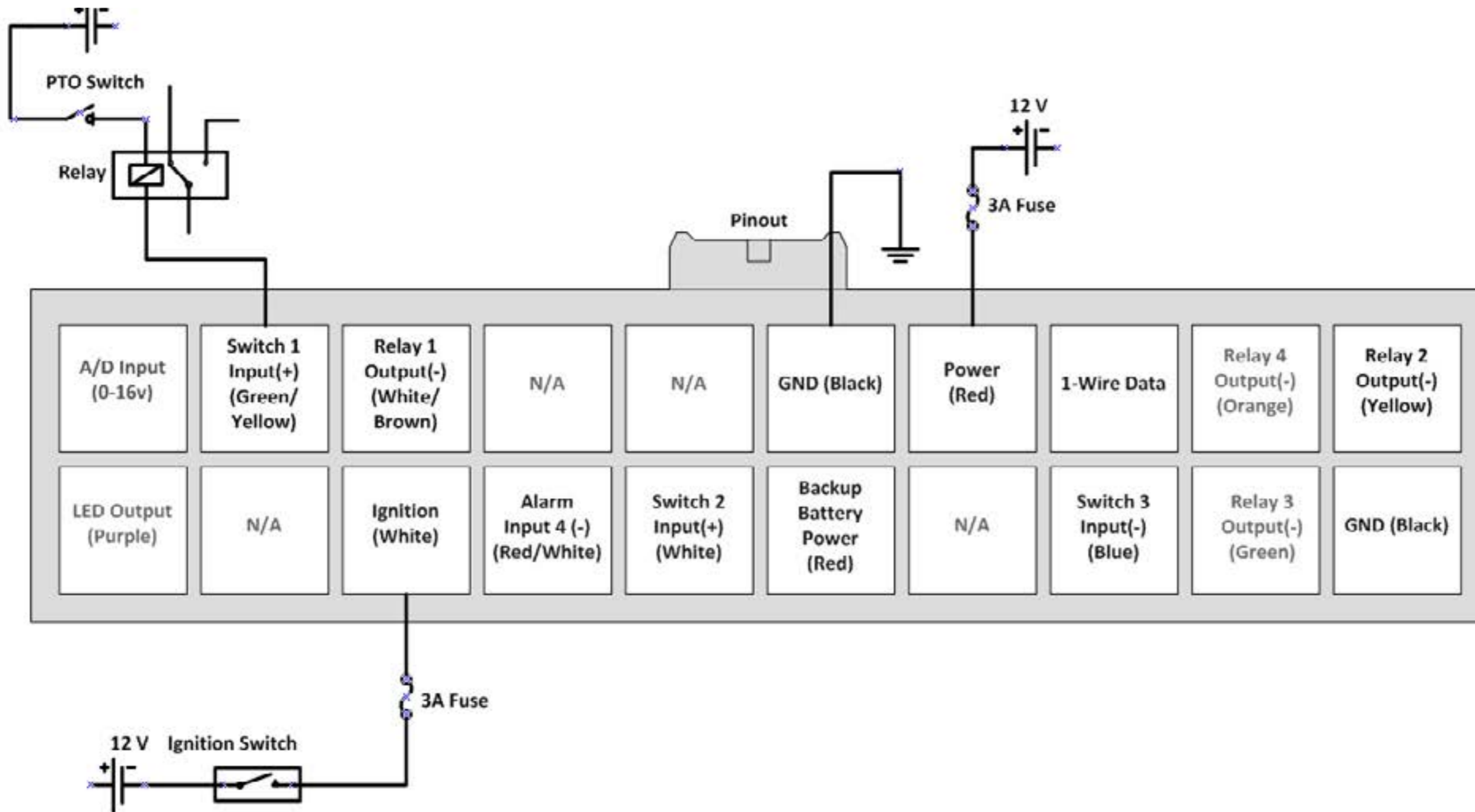

**SCHEMATIC:**  
MGS800 + RF SWITCH





# MGS800 + RF SWITCH

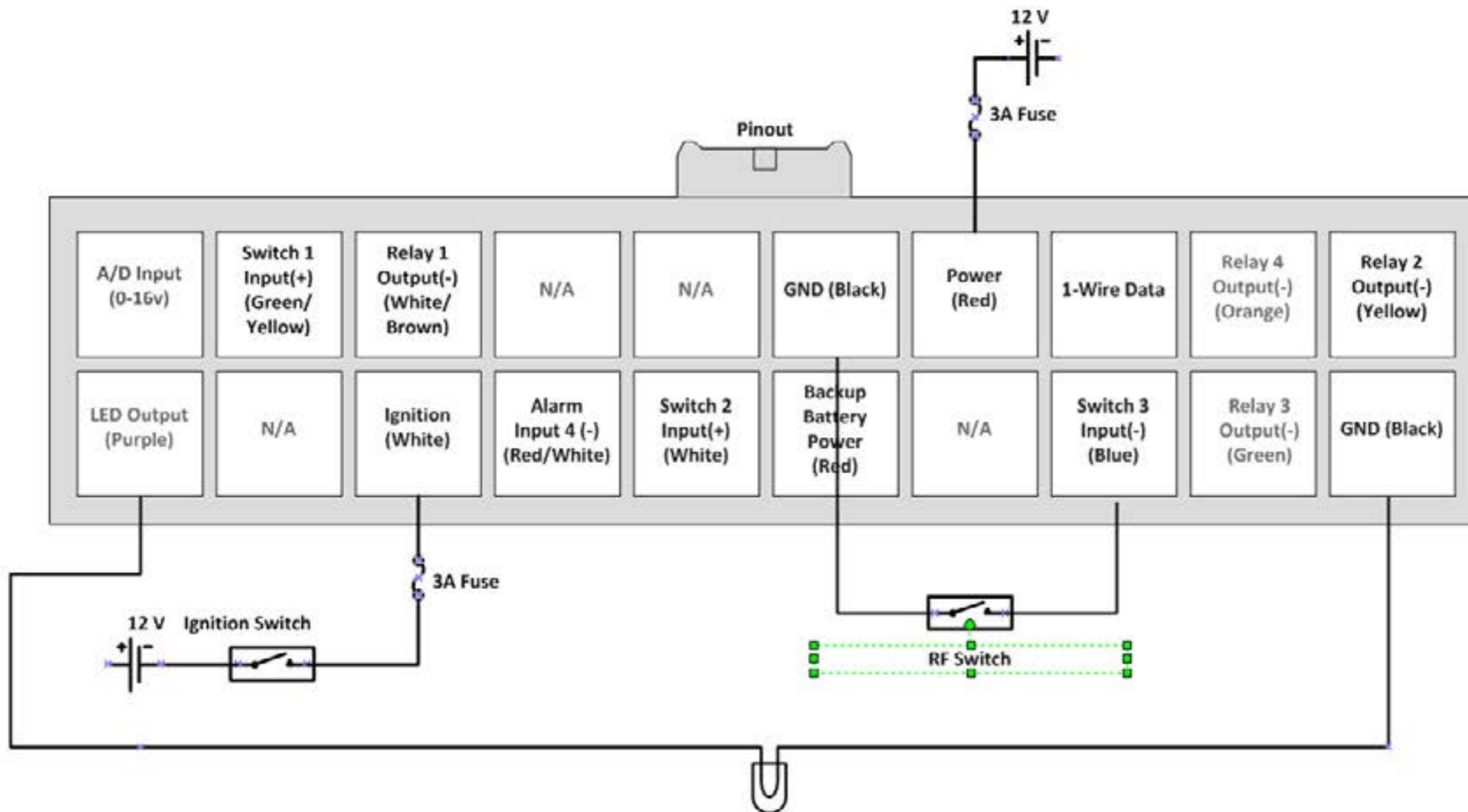

20	18	16	14	12	10	8	6	4	2
19	17	15	13	11	9	7	5	3	1

**SCHEMATIC:**  
MGS800 + TEMPERATURE SENSOR

Applies to Serial # 000003260000







## MGS800 + TEMPERATURE SENSOR

